

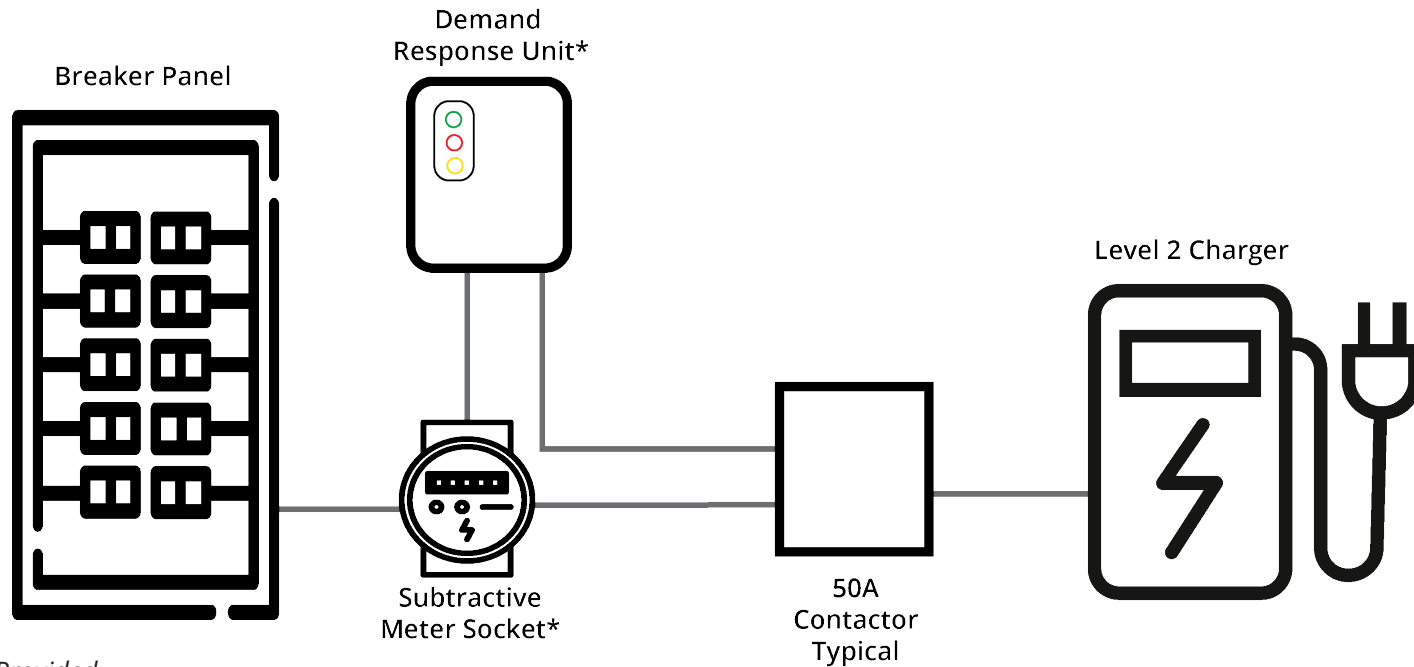

SINGLE CIRCUIT SUBTRACTIVE METERING SYSTEM ELECTRIC VEHICLE LEVEL 2 CHARGER



* Stearns Electric Association Provided

INSTRUCTIONS:

- Stearns Electric Association recommends the use of a licensed electrical contractor. Stearns Electric will not be responsible or liable for any personal injury or property damage to the wiring of, or the operation of, this or any EnergyWise® system.
- All wiring must meet National Electrical Code and be inspected by a state electrical inspector before Stearns Electric Association will check out installation.
- Any time power is off and restored to the Demand Response Unit, there will be a 15-minute time delay before unit will be allowed to operate.
- Demand Response Unit/meter socket shall be mounted 4 feet to 6 feet above the ground outside of all structures with ample access around unit.
- One (1) 30-amp set of normally closed dry contacts for controlling member supplied contactor is provided.
- 240-volts required for Demand Response Unit. This circuit may be utilized for control power as needed for contactor.
- One (1) Demand Response Unit per building is permitted.
 - Additional metered EnergyWise® programs are required to be controlled by the same Demand Response Unit and will also require separate metering equipment (*i.e., Dual Fuel*).
 - Additional un-metered EnergyWise® programs are permitted to be controlled by the same Demand Response Unit (*i.e., air conditioning or water heater - credit only*).
- Installing contractor is responsible for proper control wiring and testing before scheduling check-out appointment with Stearns Electric. Return trips may be subject to rebate reductions/delays.